

Kentruck

KENTRUCK AB
 SE - 668 32 ED • Sweden
 Tel: +46 (0)534 625 00
 Fax +46 (0)534 625 10
 E-mail office@kentruck.se
 www.kentruck.se

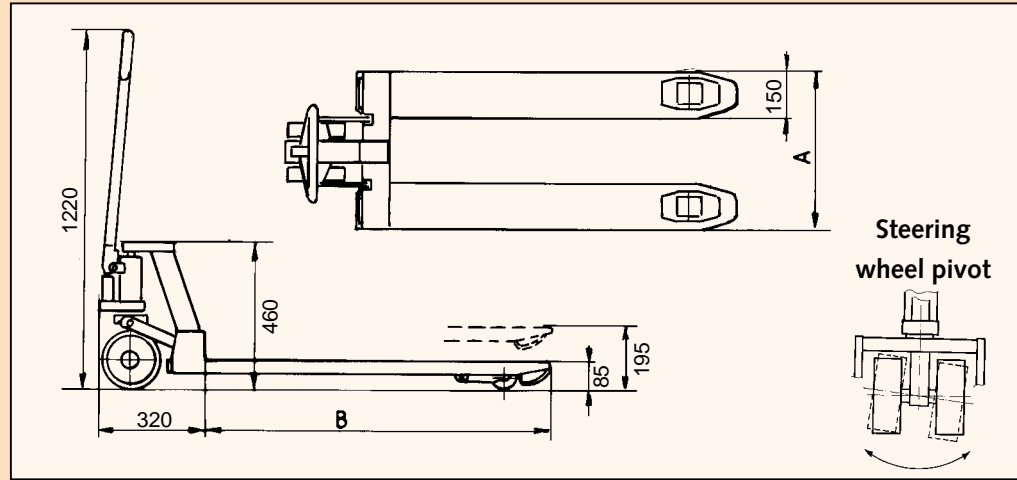

Technical specifications	SH2000	SH2500	SHQ2000	SHV2500
Steering angle	300°	300°	300°	300°
Lift capacity, kg	2000	2500	2500	2000
Fork Width, A	520-685	520-685	520-685	540
Fork width, B **	*	*	*	1180
Pump actions, full height	11	11	5	11
Quick-Lift ****	-	-	yes	-
Steering wheel pivot	yes/no	yes/no	yes/no	yes/no
Special lengths	-	**	**	-
Special widths	x			

* 800-915-1015-1150-1220 **1525-1800-2000-2200-2400 ***460-840 *****Lifts pallet from lowest position with single pump action.

Kentruck retains the right to make changes in design and specifications without prior notice.

A selection from our wide range of products



Dealer:

NEW GENERATION

Kentruck

Swan

SH-SHV 2000
 SH-SHQ 2500

The new generation
 of pallet trucks.

- Robust
- Strong
- Highly manoeuvrable



For long and heavy loads in limited space, there's only one choice! The new Swan pallet truck



With the largest steering angle available on the market, the Swan provides superior handling in confined spaces.

The Swan is the only pallet truck for handling and transporting long goods.

The new Swan has premium quality hard-chromium-plated pump and lift pistons with purpose-designed seals for heavy handling in both hot and cold temperatures. The Quick-Lift version lifts pallets clear of the floor with a single pump action.

Newly designed forks with a special sliding rail have replaced the traditional jack system ensuring smoother pallet entry.

A selection of alternative wheels are available for varying floor surfaces.

The exceptional 300° steering angle ensures excellent handling in confined spaces – especially inside vehicles and on loading ramps.

The Swan's unique design enables long loads to extend beyond the pump unit – making it ideal for exceptionally long loads.

The Swan is available in a version with a electronic scale. The SHV 2000 lifts, weights and transports in a single operation

- 4 load cells
- Microprocessor controlled
- Tara over the whole measuring range 0-1500 kg
- Accuracy: 0-600 kg/200g
601-1000 kg/500g
1001-1500 kg/1000g
- Indikator, easy to read
- Automatic shut down
- Rechargeable battery and charger included

Pallet truck Swan by *Kentruck*



Sliding extension forks for fast and simple extension.



'Easy ride' – a patented Kentruck design – enables the pallet truck to be used on gravel, paving slabs and similar outdoor surfaces



Large range of accessories